

**— CARRÉ**

LET YOUR FRAMES SHINE

**TOP** | vision  
I N S T O R E





# CONTENT

## INTRODUCTION

INSPIRATION 3

OPTICAL PRESENTATIONS RE-INVENTED 4

CREATE YOUR OWN THEATRE 5

## PRODUCT RANGE

CARRÉ STEEL SHELVING UNITS 6

CARRÉ LOCKABLE SHELVING UNITS 10

CARRÉ GLASS SHELVING UNITS 14

CARRÉ LOCKABLE COLUMN UNITS 20

CARRÉ ISLAND UNITS 26

## STYLING

AVAILABLE COLOURS 28

MOODBOARDS: CHOOSE YOUR STYLE 29

EXAMPLE CORNERS 34

## INDEPTH INFORMATION

CARRÉ STEEL IMPECABLE LIGHTING 38

CARRÉ GLASS PANEL LIGHTING 40

DESIGNTEAM 42

INSPIRATIONAL SESSIONS 43

CONTACT DETAILS 43

## WHO WE ARE

We are innovative thinkers. We are creators.

We love making beautifully designed industrial products.

We make your glasses shine. Develop the best stage for your eyewear collections.

We listen and translate your dreams into reality.

We believe in inspiring interactions. We value the uniqueness of every person and believe that your store concept should reflect your company values and identity.

Who do you want to be in this world?



## WHAT WE DO

Beautiful eyewear deserves to be shown in the very best way.

When developing products, our focus remains to present eyewear in a clear, secure, and attractive way. But over the years, we've built our knowledge upon the foundations of retailing, interior design, and technological knowledge to **make your frames shine.**

We looked at what features were missing in display solutions that were currently available, and noticed that:

Eyewear designs and colours aren't shown in their true beauty.

Traditional eyewear displays are boring and don't link the frame to the brand identity.

Designer eyewear deserves a spacious display, but should still be protected from theft.

There is no real sustainable and ecological furniture to display eyewear.

We looked for a unique way to solve these issues with our brand new Carré Shelving Units, and created eyewear specific solutions.



CARRÉ SHELVING UNITS

# OPTICAL PRESENTATIONS RE-INVENTED

We asked ourselves how to show eyewear in its true beauty?  
How to create dynamic eyewear theaters?

Everything that is alive evolves, grows and renews all the time,  
We wondered, how to create something that reflects that.

One thing we already knew:  
It's all about "Letting your frames shine"





# CREATE YOUR EYEWEAR THEATRE

Each new customer that enters your store is searching for a new impulse,  
a new scene, a new experience.

Top Vision accessories allow you to make the experience exciting and  
alive, creating regular new communicative impulses and changes,  
communicating the identity of the eyewear brands while maintaining the  
minimalistic design of your store concept.



CARRÉ STEEL SHELVING UNITS

# LARGE SHELVING UNITS

The Carré Optical Steel shelving displays are the ultimate horizontal presentation to express your unique brands. Each frame is individually highlighted by ten LED lighting spots that provide a lively bright image and make your eyewear stand out.

These displays are available in five chassis colours and four background colours, and any combination is possible. Use the configurator to create your ideal version.



- ULTIMATE LIGHT
- INDIVIDUAL ATTENTION
- DYNAMIC BRAND EXPOSURE



## CARRÉ STEEL SHELVING UNITS

# PRODUCT SPECIFICATIONS

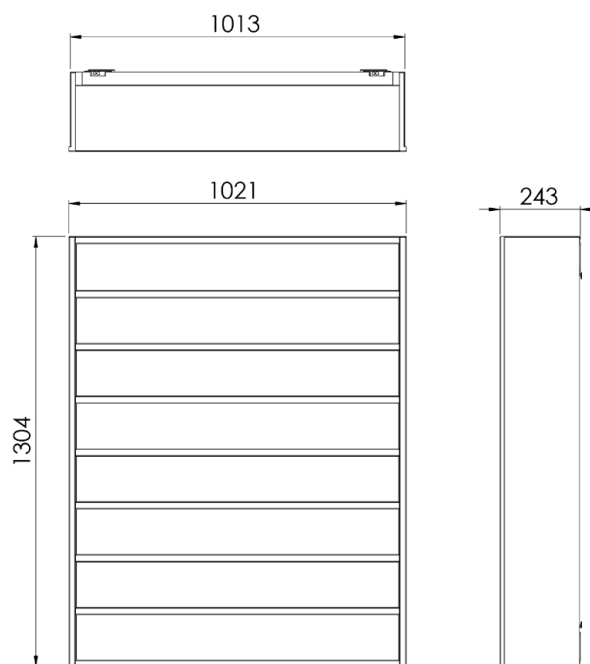

### CARRÉ STEEL SHELVING UNITS 8 X 5

- Starting from € 2.350,-
- Article number: Carré CS.8x5
- Type of presentation: Non-locked
- Number of presentations: 40 frames
- Number of presentation levels: 8
- Size: H 1304mm x W 1021mm x D 243mm
- Weight: 63 kg
- Material: Main frame steel with steel shelves
- Unit mass on the wall: 155 kg
- Maximum load-bearing capacity of the shelves:  
5 kg per shelf
- Light: 10 led-light spots for each pair of frames
- Light intensity: 6100 lux for each pair of frames  
(depending on circumstances)
- Light colour: 4000 Kelvin
- Additional ceiling light: best use with wall washers

Read more on Carré steel individual led-spot lights in-depth information on page 34.



CARRÉ STEEL SHELVING UNITS

## LUXURY SHELVING UNITS

Carré steel shelving units are also available as compact and impactful box styled units or horizontal styled units with three presentation levels.

These luxury shelving units are designed for your most exclusive eyewear.

It's the ultimate way to display the true value of your high-end brands.



- ULTIMATE LIGHT
- INDIVIDUAL ATTENTION
- EXCLUSIVE BRAND EXPOSURE

## LUXURY STEEL SHELVING UNITS

## PRODUCT SPECIFICATIONS

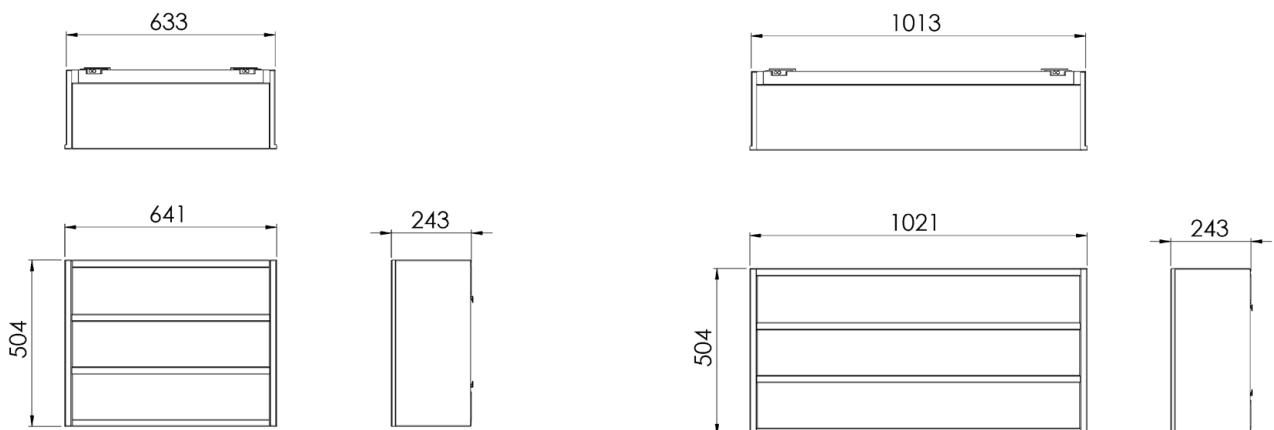

## CARRÉ STEEL SHELVING UNITS 3 X 3

- Starting from € 1.075,-
- Article number: Carré CS.3x3
- Type of presentation: Non-locked
- Number of presentations: 9 frames
- Number of presentation levels: 3
- Size:H 504mm x W 641mm x D 243mm
- Weight: 21,5 kg
- Material: Main frame steel with steel shelves
- Unit mass on the wall: 54,75 kg
- Maximum load-bearing capacity of the shelves: 5 kilo per shelf
- Light: 10 led-light spots for each pair of frames
- Light intensity: 6100 lux for each pair of frames (depending on circumstances)
- Light colour: 4000 Kelvin
- Additional ceiling light: best use with wall washers

Read more on Carré steel individual led-spot lights in-depth information on page 38.

## CARRÉ STEEL SHELVING UNITS 3 X 5

- Starting from € 1.175,-
- Article number: Carré CS.3x5
- Type of presentation: Non-locked
- Number of presentations: 15 frames
- Number of presentation levels: 3
- Size:H 504mm x W 1021mm x D 243mm
- Weight: 28 kg
- Material: Main frame steel with steel shelves
- Unit mass on the wall: 64,5 kg
- Maximum load-bearing capacity of the shelves: 5 kilo per shelf
- Light: 10 led-light spots for each pair of frames
- Light intensity: 6100 lux for each pair of frames (depending on circumstances)
- Light colour: 4000 Kelvin
- Additional ceiling light: best use with wall washers

Read more on Carré steel individual led-spot lights in-depth information on page 38.

CARRÉ LOCKABLE SHELVING UNITS

# LOCKABLE SHELVING UNITS

The Carré Lockable eyewear shelving displays are the ultimate presentation for luxury frames, that deserve more attention, require impeccable lighting and need to be protected against theft. By choosing this lockable solution, you can easily create an environment where both you and your customer feel at ease.

These units feature lighting modules of ten LEDs per individual frame, that provide a lively bright image and make your eyewear stand out. The locking mechanism is operated by a remote control with a personal code for the swift opening and closing of your eyewear presentations.

We created a high-end product, where the engine of the lockable technology is integrated inside each lockable module. So, each frame has its own motor drive. The use of gold-plated circuit board connections creates a stable power network for each individual lock module.



- LOCKABLE PRESENTATION
- ULTIMATE ILLUMINATION
- INDIVIDUAL PRESENTATION
- CREATES BRAND AWARENESS



## CARRÉ LOCKABLE SHELVING UNITS

# PRODUCT SPECIFICATIONS

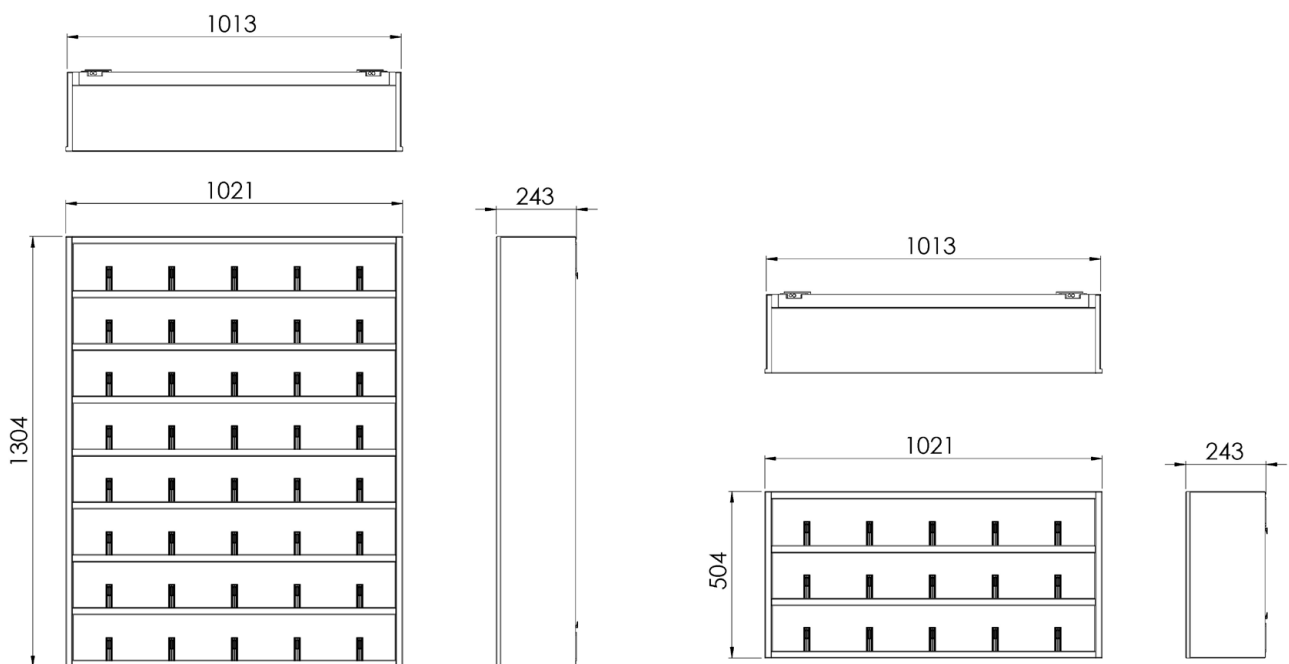

### CARRÉ LOCKABLE SHELVING UNITS 8 X 5

- Starting from € 4.970,-
- Article number: Carré CSR.8x5
- Type of presentation: Lockable with remote control
- Number of presentations 40 brillen
- Number of presentation levels: 8
- Size: H 1304 mm x B 1021 mm x D 243 mm
- Weight: 67 kilo
- Material: Main frame steel with steel shelves
- Unit mass on the wall: 155 kilo
- Maximum load-bearing capacity of the shelves: 5 kilo per shelf
- Light: 10 led-light spots for each pair of frames
- Light intensity: 6100 lux for each pair of frames (depending on circumstances)
- Light colour: 4000 Kelvin
- Additional ceiling light: best use with wall washers

Read more on Carré steel individual led-spot lights in-depth information on page 38.

### CARRÉ LOCKABLE SHELVING UNITS 3 X 5

- Starting from € 2.545,-
- Article number: Carré CSR.3x5
- Type of presentation: Lockable with remote control
- Number of presentations 15 brillen
- Number of presentation levels: 3
- Size: H 504mm x W 1021mm x D 243mm
- Weight: 29 kilo
- Material: Main frame steel with steel shelves
- Unit mass on the wall: 64,5 kilo
- Maximum load-bearing capacity of the shelves: 5 kilo per shelf
- Light: 10 led-light spots for each pair of frames
- Light intensity: 6100 lux for each pair of frames (depending on circumstances)
- Light colour: 4000 Kelvin
- Additional ceiling light: best use with wall washers

Read more on Carré steel individual led-spot lights in-depth information on page 38.

CARRÉ STEEL SHELVING UNITS

# IMPECCABLE EYEWEAR ILLUMINATION

Now available, our state-of-the-art LED lighting systems, which are integrated in the new Carré steel shelving units by using our uniquely developed chipset. By using ten spotlights per frame, these new shelves can highlight each frame individually, using intelligent chipsets where energy is transmitted equally to all spotlights. This new invention, allows ultimate focused and naturally balanced light, to showcase each individual frame.



CARRÉ STEEL SHELVING UNITS

# THE BEST EYEWEAR STAGE

Each unit is a theater on its own. What we developed is a stage for each frame. For your eyewear and brands to pop-out, shine and make them visible into the world. Effective tools for you to deliberately highlight specific eyewear. Our smart designed accessories benefit from existing integrated led lights for a bright brand exposure.





CARRÉ GLASS SHELVING UNITS

# LARGE GLASS SHELVING UNITS

The Carré glass shelving units is a transparent shelving system with a minimalistic look, which pure and clean design emphasizes the focus on your frames. The top panel led-light reduces the cast shadow, to create a clean and calm view on the eyewear.



- FULL COLLECTION FOCUS
- TRANSPARENCY
- BALANCED LIGHT
- ELIMINATES CAST SHADOW

## CARRÉ GLASS SHELVING UNITS

# PRODUCT SPECIFICATIONS

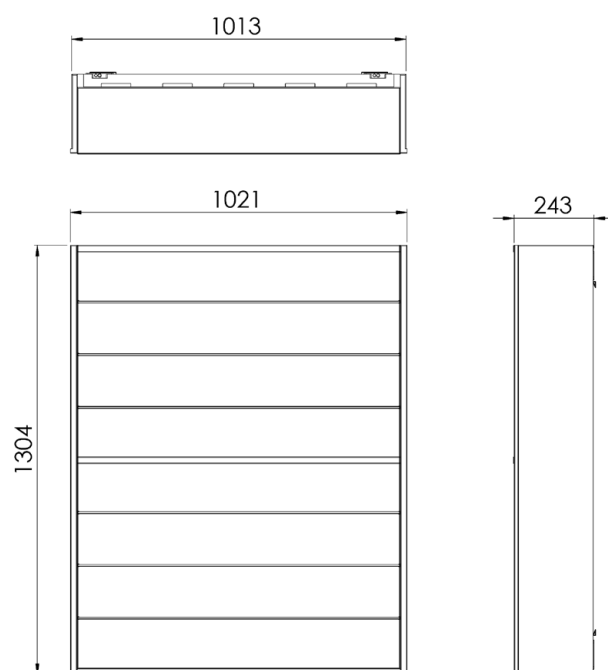

### CARRÉ GLASS SHELVING UNITS 8 X 5

- Starting from € 1.785,-
- Article number: Carré GS.8x5
- Type of presentation: Non-locked
- Number of presentations: 40 frames
- Number of presentation levels: 8
- Size: H 1304mm x W 1021mm x D 243mm
- Weight: 60 kg
- Material: main frame steel with glass shelves
- Unit mass on the wall: 150 kg
- maximum load-bearing capacity of the shelves: 5 kg per shelf
- Light: Two top panel lights, one for each segment.
- Light intensity: Depending on the presentation level (see specifications on page 36)
- Light colour: 4000 Kelvin
- Additional ceiling light: best use with wall washers

Read more on Carré glass top panel led-lights in-depth information on page 40.

CARRÉ GLASS SHELVING UNITS

# LUXURY SHELVING UNITS

Carré glass shelving units are also available as compact and impactful box styled units or horizontal styled units with three presentation levels. These luxury shelving units are designed for your most exclusive eyewear. It's the ultimate way to display the true value of your high-end brands.



- LUXURY STATEMENT
- MAXIMUM ATTENTION
- FREEDOM
- ULTIMATE / BALANCED LIGHT



## LUXURY GLASS SHELVING UNITS

## PRODUCT SPECIFICATIONS

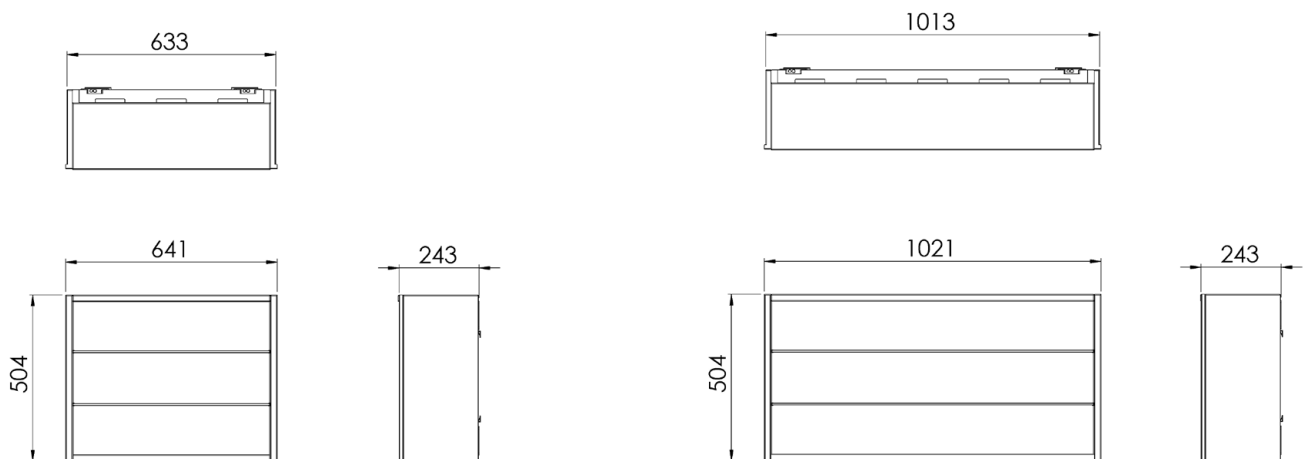

## CARRÉ GLASS SHELVING UNITS 3 X 3

- Starting from € 787,-
- Article number: Carré GS.3x3.
- Type of presentation: Non-locked
- Number of presentations: 9 frames
- Number of presentation levels: 3
- Size: H 504mm x W 641mm x D 243mm
- Weight: 20 kg
- Material: main frame steel with glass shelves
- Unit mass on the wall: 52,5 kg
- Maximum load-bearing capacity of the shelves: 5 kilo per shelf
- Light: Two top panel lights, one for each segment.
- Light intensity: Depending on the presentation level
- Light colour: 4000 Kelvin
- Additional ceiling light: best use with wall washers

Read more on Carré glass top panel led-lights  
in-depth information on page 40.

## CARRÉ GLASS SHELVING UNITS 3 X 5

- Starting from € 875,-
- Article number: Carré GS.3x5.
- Type of presentation: Non-locked
- Number of presentations: 15 frames
- Number of presentation levels: 3
- Weight: 26 kg
- Size: H 504mm x W 1021mm x D 243mm
- Material: main frame steel with glass shelves
- Unit mass on the wall: 61,5 kg
- Maximum load-bearing capacity of the shelves: 5 kilo per shelf
- Light: Two top panel lights, one for each segment.
- Light intensity: Depending on the presentation level
- Light colour: 4000 Kelvin
- Additional ceiling light: best use with wall washers

Read more on Carré glass top panel led-lights  
in-depth information on page 40.

CARRÉ GLASS CAPACITY UNITS

# CAPACITY, STORAGE AND MIRROR

Carré glass shelving units are also available with a smaller presentation grid, creating a higher capacity of illuminated presentations, or a non illuminated version that is fitted with a mirror door, which is ideal for storage.

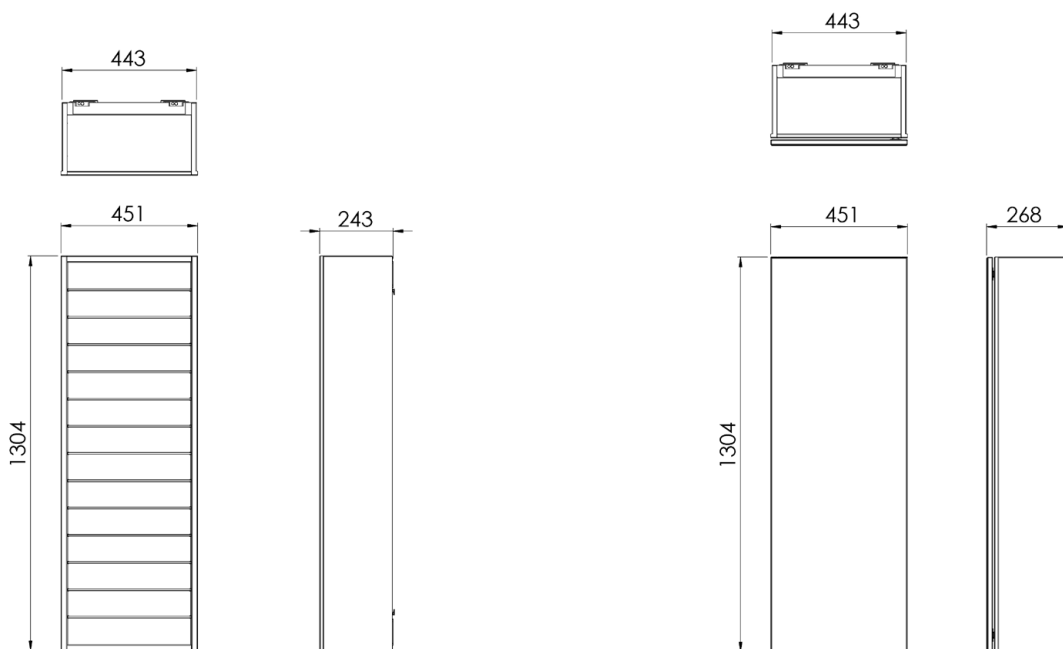

## CARRÉ GLASS CAPACITY UNIT 14 X 2

- Starting from € 1.080,00
- Article number: Carré CGC.14x2
- Type of presentation: Non-locked
- Number of presentations: 28 frames
- Size: H 1304mm x W 451mm x D 243mm
- Weight: 41 kg
- Unit mass on the wall: 167 kg
- Material: Main frame steel and glass shelves
- Required load-bearing capacity of the wall: 5 kg
- Light: Top panel light
- Light intensity: Depending on the presentation level
- Light colour: 4000 Kelvin
- Additional ceiling light: best use with wall washers

## CARRÉ STORAGE & MIRROR DOOR UNIT

- Starting from € 980,00
- Article number: Carré CSM.14x2
- Type of use: Mirror and storage
- Number of storage levels: 14
- Size: H 1304mm x W 451mm x D 243mm
- Weight: 79 kg
- Unit mass on the wall: 119 kg
- Material: Main frame and door steel with acryl shelves
- Required load-bearing capacity of the wall: 2 kg
- Light: No light available

CARRÉ GLASS UNITS

# NEXT LEVEL TOP PANEL LIGHT

Introducing a newly developed top panel light system for the Carré glass shelving units with more than triple the light production per cm<sup>2</sup>. Amplifying a pure, clean and natural look for each frame. All with groundbreaking energy efficiency.





CARRÉ LOCKABLE COLUMN UNITS

# REMOTE CONTROLLED UNITS

The Carré units with vertical lockable presentations (columns) for your high-end sunglasses, create a high-capacity presentation, illuminated with top panel light encased within the minimalistic Carré design concept.

These rods are operated by a remote control with a personal code for swift and comfortable opening and closing.



- HIGH CAPACITY
- SECURE SUNGLASS PRESENTATION
- BALANCED LIGHT
- ELIMINATES CAST SHADOW

## CARRÉ LOCKABLE SHELVING UNITS (REMOTE)

# PRODUCT SPECIFICATIONS

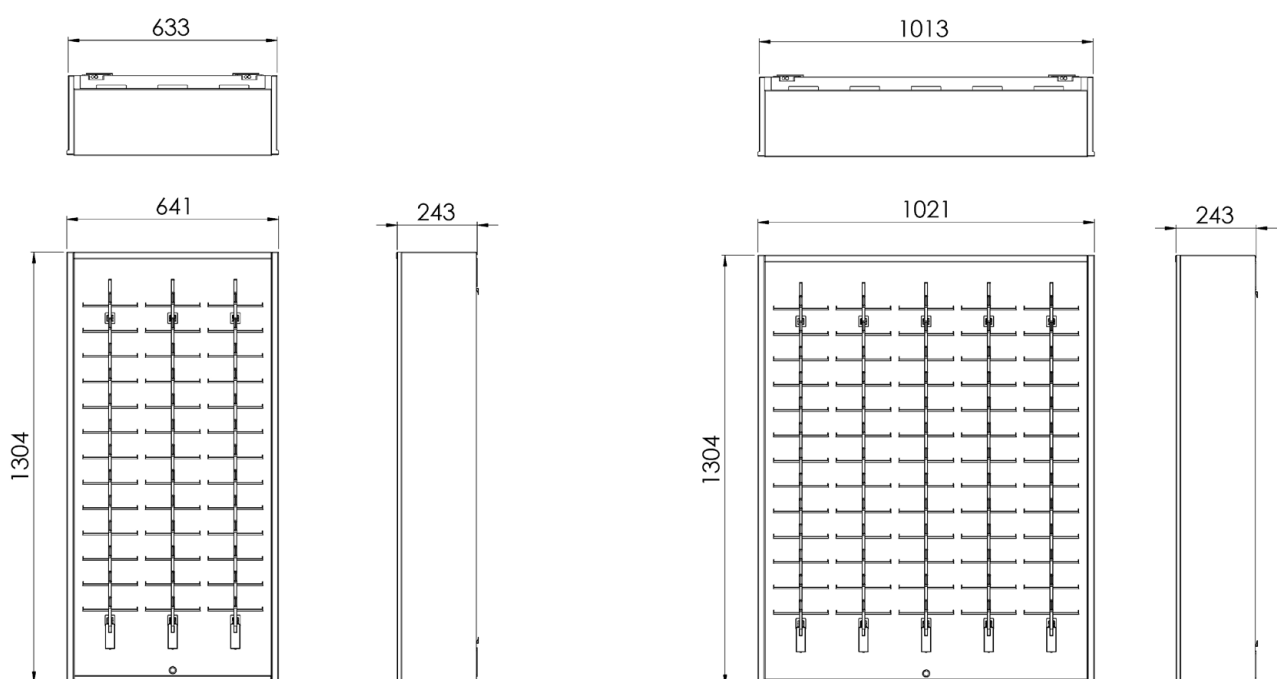

### CARRÉ LOCKABLE COLUMN UNITS - REMOTE CONTROLLED 13 X 3

- Starting from € 2.030,-
- Article number: Carré CAR.13x3
- Type of presentation: remote lockable
- Number of presentations: 39 frames
- Size: H 1304mm x W 1641mm x D 243mm
- Material: Main frame Steel with aluminium rods
- Light: Top panel light
- Light intensity: Depending on the presentation level
- Light colour: 4000 Kelvin
- Additional ceiling light: best use with wall washers

Read more on Carré glass top panel led-lights  
in-depth information on page 40.

### CARRÉ LOCKABLE COLUMN UNITS - REMOTE CONTROLLED 13 X 5

- Starting from € 2.350,-
- Article number: Carré CAR.13x5
- Type of presentation: remote lockable
- Number of presentations: 65 frames
- Size: H 1304mm x W 1021mm x D 243mm
- Weight: 46 kg
- Material: Main frame Steel with aluminium rods
- Unit mass on the wall: 69 kg
- Light: Top panel light
- Light intensity: Depending on the presentation level
- Light colour: 4000 Kelvin
- Additional ceiling light: best use with wall washers

Read more on Carré glass top panel led-lights  
in-depth information on page 40.

CARRÉ LOCKABLE COLUMN UNITS

## KEY-LOCKED UNITS

The key-locked version of the lockable Carré units feature a user-friendly and strong key-lock system that opens smoothly .





## CARRÉ LOCKABLE SHELVING UNITS (KEY)

# PRODUCT SPECIFICATIONS

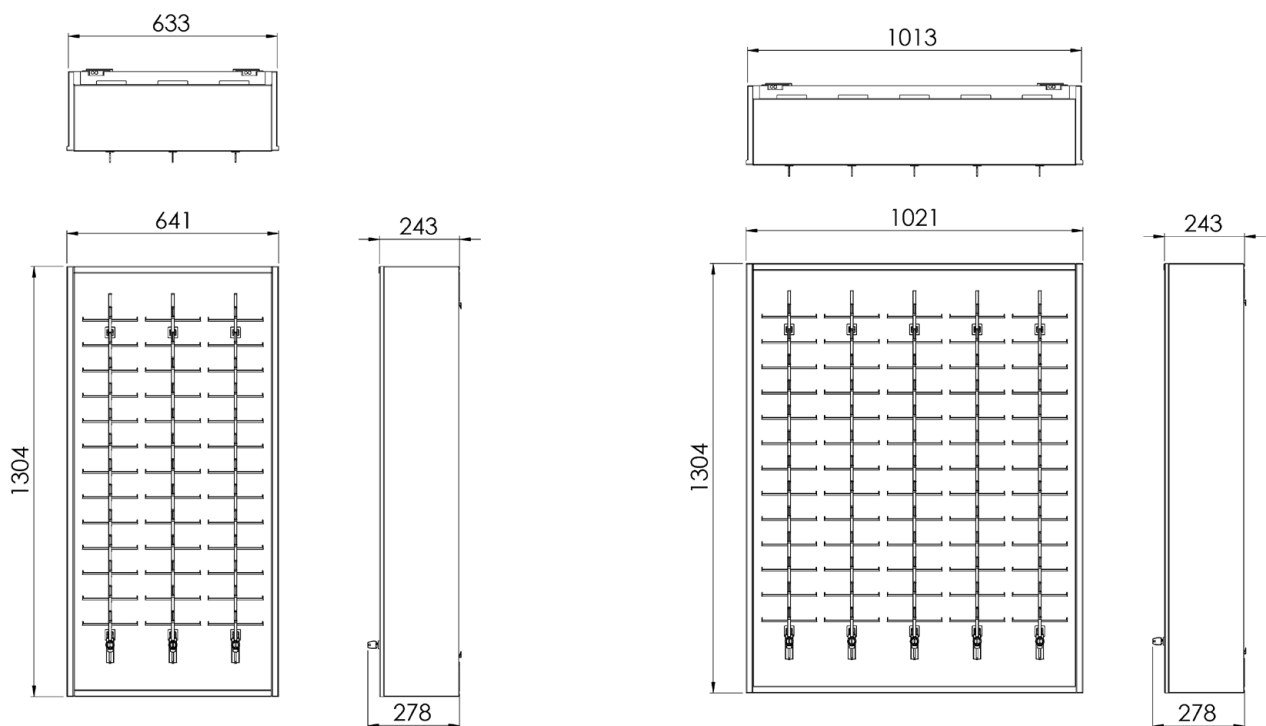

### CARRÉ LOCKABLE COLUMN UNITS – KEY-LOCKED 13 X 3

- Starting from € 1.550,-
- Article number: Carré CAK.13x3
- Type of presentation: key-lock lockable
- Number of presentations: 39 frames
- Size: H 1304mm x W 1641mm x D 243mm
- Material: Main frame Steel with aluminium rods
- Light: Top panel light
- Light intensity: Depending on the presentation level
- Light colour: 4000 Kelvin
- Additional ceiling light: best use with wall washers

Read more on Carré glass top panel led-lights in-depth information on page 40.

### CARRÉ LOCKABLE COLUMN UNITS – KEY-LOCKED 13 X 5

- Starting from € 1.750,-
- Article number: Carré CAK.13x5
- Type of presentation: key-lock lockable
- Number of presentations: 65 frames
- Size: H 1304mm x W 1021mm x D 243mm
- Weight: 46 kg
- Material: Main frame Steel with aluminium rods
- Unit mass on the wall: 69 kg
- Light: Top panel light
- Light intensity: Depending on the presentation level
- Light colour: 4000 Kelvin
- Additional ceiling light: best use with wall washers

Read more on Carré glass top panel led-lights in-depth information on page 40.



For Hartger Fijten of Tempel Optiek, his store is like his second home. Here he likes to surprise customers in a rock and roll atmosphere.

With the illuminated Carré cabinets and the poster boxes, his luxury glasses are now finally clearly visible and the true acetate colors can be seen.

Hartger and his team are very happy with this solution and the sunglasses stand out even more with customers.







# CARRÉ ISLAND

Carré Island units float in front of your customer as they browse your latest collections, offers and themes. The possibilities are endless as your floorspace hosts ever-changing configurations, pulling customers toward the island which acts as a focus point for sales optimization.



- HIGHLIGHT SPECIFIC COLLECTIONS & THEMES
- TRIGGER POTENTIAL BUYERS TO ENTER YOUR STORE
- CREATE IMPULS SALES

CARRÉ ISLAND UNITS

# PRODUCT SPECIFICATIONS

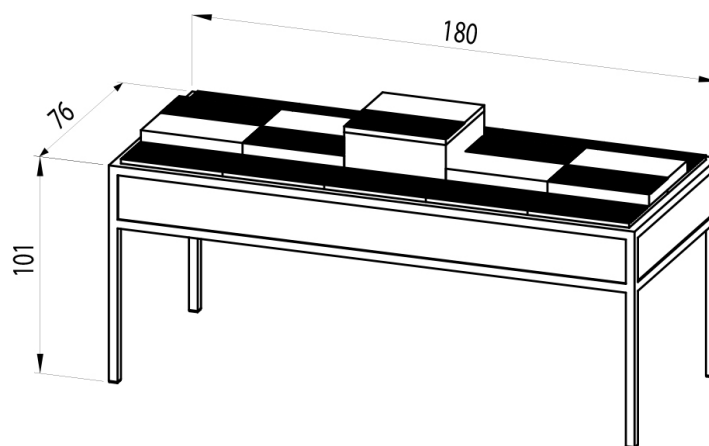

## CARRÉ ISLAND

- Starting from € 1.875,00
- Article number: Carré 58799
- Type of presentation: Non-locked
- Number of presentations: 30 to 40
- Size: H 1010mm x W 1800mm x D 760mm
- Material: Main frame steel. MDF base and acrylic tableaus
- Colors: Main frame black, base white, tableaus white

# CARRÉ COLOURS

Colour influences perception. The colours you use in your store design can have a profound impact on your shoppers. Every colour used in your store tells a story that will determine how shoppers perceive your merchandise. The right store colour can enhance your message and overall brand appeal. In fact, colour psychology can lead to fewer objections to the purchase, irrespective of the price.

That is why we created a variety of chassis and background colours for you to choose from. To make sure your eyewear is showcased in the best atmosphere, but to also give your store the right identity  
Your identity!

## CARRÉ CHASSIS COLOURS

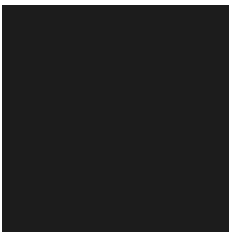

Black fine structure  
RAL 9005

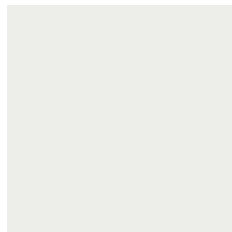

Traffic white matt  
RAL 9016

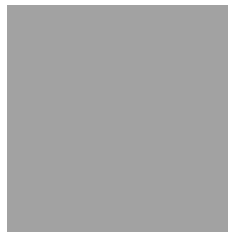

Window Grey  
fine structure  
RAL 7040

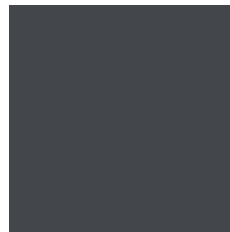

Graphite Grey  
fine structure  
RAL 7024



Timeless rust  
fine structure

## CARRÉ BACKGROUND COLOURS



Tele grey fine structure  
RAL 7047



Grey white fine structure  
RAL 9002



Light grey & light blue  
fine structure

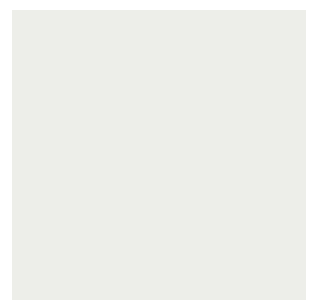

Traffic white fine structure  
RAL 9016



# CHOOSE YOUR STYLE

What you as a company stand for matters.  
That's how you distinguish yourself and attract your target group.  
We believe, that, who you are, your identity, your company team  
values should be felt in the retail store experience.  
Always...

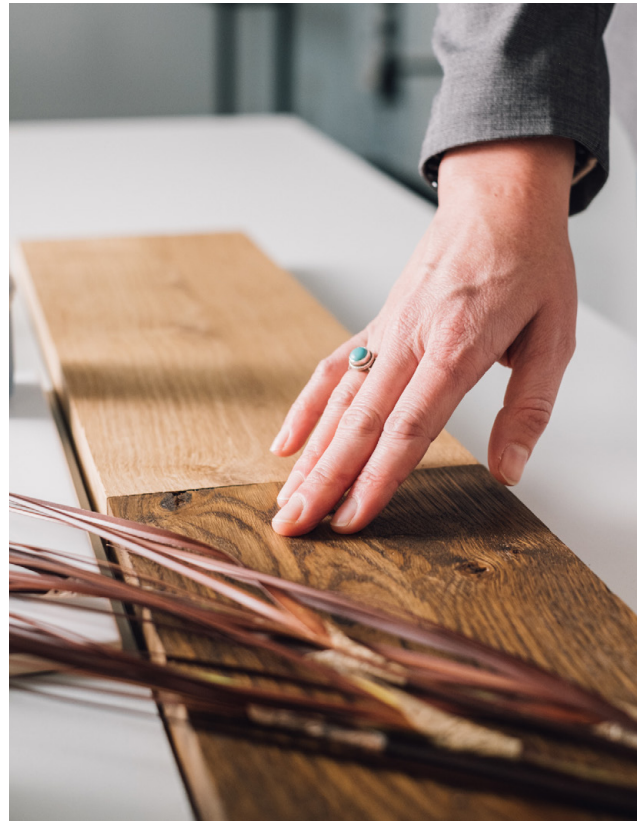

## MOODBOARDS

**Join us in a journey to determine your identity and translate it into a store concept.**

Moodboards are a powerful tool to determine the essential elements of your store concept. Who do you want to be as a company? Which materials, colours and combinations embody your company identity? Check out our latest moodboards.

## SCANDINAVIAN

Scandinavian design is characterized by a minimal clean approach that seeks to combine functionality with beauty. Its focus is on simple lines and light airy spaces, devoid of clutter





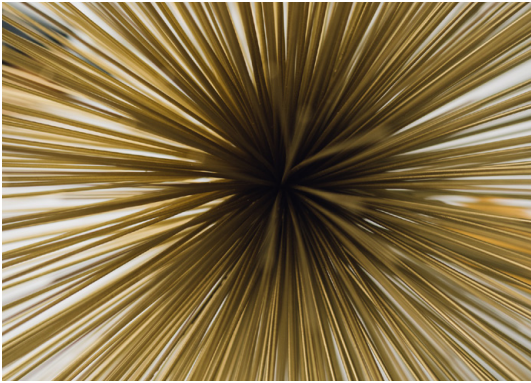

## WHITE AND GOLD

White interiors are like an untouched canvas, where the possibilities are endless, and gold is instantly synonymous with luxury design and a sense of opulence and exclusivity.





## BLUE AND WHITE COMBINATION

The classic combination of blue and white creates a feeling of freshness and lightness. Warm sand and beige shades perfectly complement the blue, making it warmer.







## BLACK AND GOLD

The use of a single, powerful colour is a simple, beautiful way to enhance a space, but when an interior embraces two complementary hues that were destined to sit side by side, like black and gold, impact and attitude are accelerated to the next level.



# INSTORE RENEWAL. ULTIMATE PERFORMANCE

We created a minimalistic design and modular units, giving you the freedom to be flexible. To create and recreate new instore experiences, by continuous renewal of your instore backdrops (wall painting, wall paper, etc.).

Making frequent large impact changes with smart investments that will boost your sales performance.

Here are three example corners, that perfectly stand out in a variety of interior designs.



# BOUTIQUE

Customers who come to your store for the most exclusive glasses should be pampered. Decorate your corner with the Carré box units so that your luxury collections are pulled to a higher level.



## EXAMPLE CORNER #1

4 square luxury glass shelving units for 9 frames each plus a storage unit with mirror.





# NATURAL

Some brands deserve more attention and a distinct segmentation. Our landscape Carré units illuminate each frame individually and show its beauty and true colors.



## EXAMPLE CORNER #2

4 horizontal steel shelving units for 15 frames each plus a storage unit with mirror.





# INDUSTRIAL

Fashionable frames require special attention. Our large Carré units allow more freedom in presentation. With our accessories, you can create individual theaters per frame and reinforce brands with illuminated branding boxes.



## EXAMPLE CORNER #3

2 large steel shelving units for 40 frames each plus a storage unit with mirror.



CARRÉ STEEL: IMPECCABLE LIGHT

# INDEPTH INFORMATION

The completely newly-developed Carré LED technology has 20 individual LED lights for each pair of frames. The integrated light elements in the steel Carré shelves are positioned at the front of the shelf in the best angle so that they light up the front of the glasses, while the reflection of the rear wall provides complete illumination. This ensures the best combination between direct and indirect light. The space between the light spots provides a lively bright image, which makes each frame stand out fully.

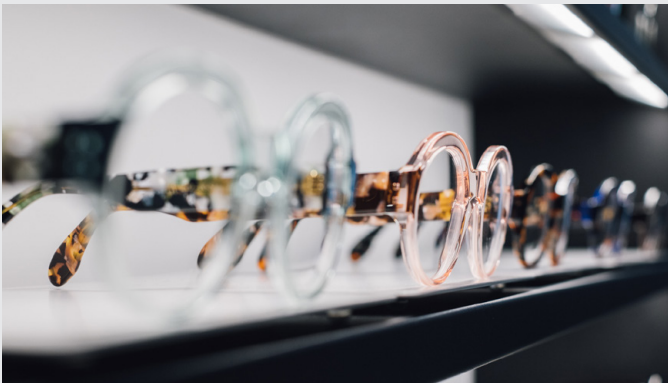

## STABLE LIGHT

The Carré steel chipset LED system guarantees a constant power supply for each light source equally and is fully electronically controlled. This system guarantees completely continuous light, without any flickering. The result: stable light, for every pair of glasses, creating a calm and unambiguous light image where the focus on the glasses is inviting and comfortable.

## OPTIMAL BALANCED LIGHT

A balanced spectrum of light intensity and colour is essential to make glasses look really as they are and express their true beauty. Light is invisible to the human eye and only becomes visible to us because it reflects on an object. The quality, how glasses are illuminated, is determined by the light spectrum present in the white light. This is how it works: A LED light of only a few millimeters projects itself through an emulsion layer which is filled with a high-quality complex formula of the phosphors. The quality of the emulsion layer determines the specifics of the colour spectrum. Where low-cost led-lighting has a limited colour rendering of less than 60 CRI (colour rendering index). Top Vision has opted for a balanced colour rendering (CRI >80) with optimal natural light (Osram).



CRI &lt;70

CRI &gt;70 - &lt;80

CRI &gt;80

## LIGHT INTENSITY & CEILING LIGHT

The Carré steel shelving units with 20 individual LED lights for each frame has a light colour of 4000 Kelvin and an average light intensity of 6150 Lux for each pair of frames \*. The combination with the ceiling lighting consisting of wall washes tailored to the situation creates a lively and natural light image. The use of additional ceiling light in combination with the 20 individual LED lights for each frame creates the most optimal product display.

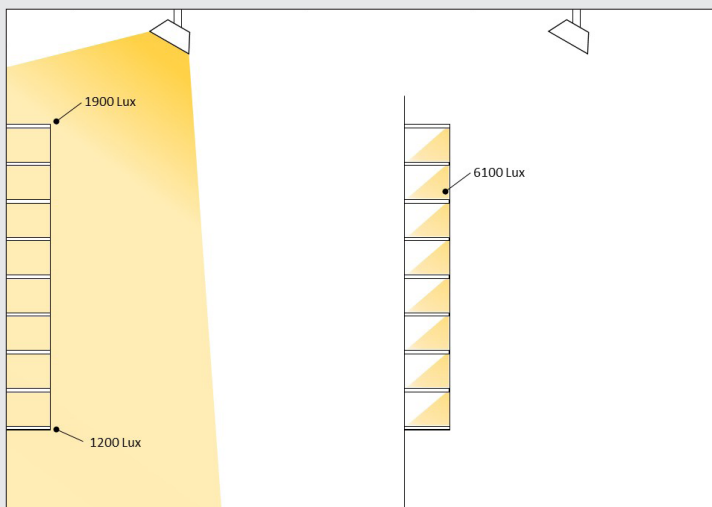

Additional ceiling light intensity requirements for the best results.

Carré steel shelving units with a light intensity of 6100 Lux per frame.

\*depending on local circumstances

## HIGHEST CLASS IN EFFICIENCY

In regular LED applications without control, the light intensity is determined by resistors. Top Vision has developed special LED driver-chips, without the use of dissipation resistors. Due to this electronic control, the energy is delivered very constantly and almost all energy is converted to the LED lights. The heat development is therefore extremely low. The less heat loss, the more durable. The result? Long life and higher efficiency of the light source.

## EASE OF SERVICE

The use of printed circuit board connections in the unit creates a stable power network. With service, this has a great additional convenience, which allows modular parts to easily be replaced locally.





## CARRÉ GLASS: TOP PANEL LIGHT

## INDEPTH INFORMATION

The Carré glass shelving unit with Panel Top light creates a natural appeal and reduces the cast shadow so that the image of the glasses is calm and the glasses are completely central to the perception.

LED light panels as used in contemporary architecture were not enough for us. For the Carré glass units we needed homogeneous lighting with 3 x more light intensity to realistically represent every pair of glasses. We have developed our own luminaire for this.



## CRYSTAL CLEAR LIGHT GUIDES

The Carré Glass shelving units use newly developed LED panels that act as crystal clear light guides. LED spots that are placed around the LED panel distribute the light at regular intervals. The thickness, quality and processing of the LED panel determines the even light. This ensures minimal light loss and optimal homogeneous natural light.

## OPTIMAL BALANCED LIGHT

A balanced spectrum of light intensity and colour is essential to make glasses look really as they are and express their true beauty. Light is invisible to the human eye and only becomes visible to us because it reflects on an object. The quality, how glasses are illuminated, is determined by the light spectrum present in the white light.

This is how it works: A LED light of only a few millimeters projects itself through an emulsion layer which is filled with a high-quality complex formula of the phosphors. The quality of the emulsion layer determines the specifics of the colour spectrum. Where low-cost led-lighting has a limited colour rendering of less than 60 CRI (colour rendering index). Top Vision has opted for a balanced colour rendering (CRI >80) with optimal natural light (Osram).



CRI &lt;70

CRI &gt;70 - &lt;80

CRI &gt;80

## CEILING LIGHT

The Carré glass shelving units with top panel light has a light colour of 4000 Kelvin. This is a bright white colour. The combination with the ceiling lighting consisting of wall washes tailored to the situation creates a lively and natural light image. The use of additional light in combination with the top panel light creates the required and most optimal product display.

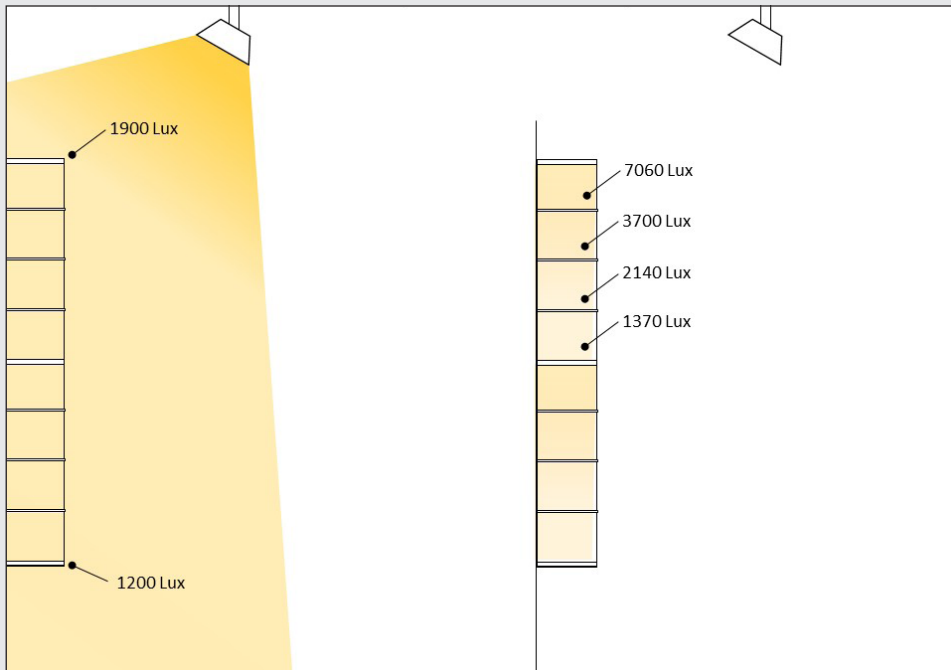

Additional ceiling light intensity requirements for the best results.

Carré glass shelving units with a light intensity of 7060 to 1370\* Lux per shelf / per frame.

\*depending on local circumstances



## EFFICIENCY

The latest LED technology and in-house developed electronic chipsets guarantee maximum conversion of energy into light with the highest light output (3 x more light) and only 1.6 times the energy consumption. With heat management that is electronically organized and heat dissipation through integrated cooling fins, a sustainable solution has been created with an optimal lifespan of the light sources.

## HEAT DISSIPATION

With an electronically controlled heating system and heating discharge through integrated cooling fins, a sustainable solution has been created which guarantees an optimum lifespan of the light sources.



# DESIGNTEAM

We love making beautiful industrial designed products.

For more than 30 years we created sophisticated designed columns for lockable and nonlockable presentations. In this new decade we want to present a complete new instore system.

Simplicity, functionality elegance are the calling cards for our design.

A neutral, characteristic, minimalistic versatile assortment.

For you the opportunity to create your world.

Creating the best podium for your frames.

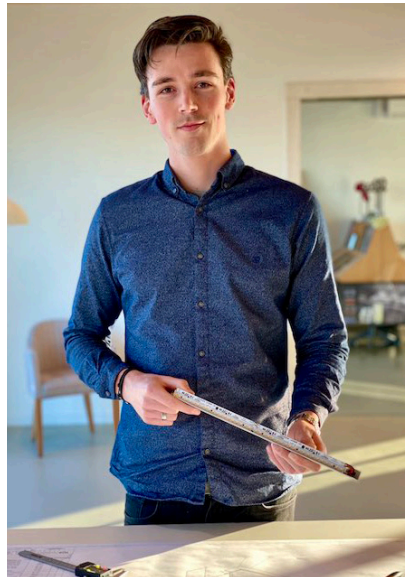
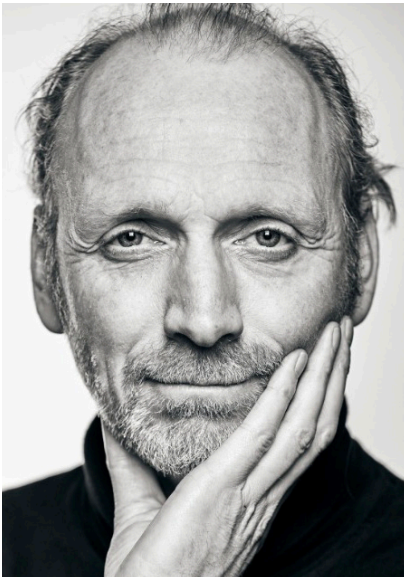



CARRÉ SHELVING INSPIRATION SESSION

# AN INVITATION TO YOU

Get inspired, join us in this adventure,  
discover what is now available, make your own choices.  
Let's create an eyewear theater. We offer the lighting, the stage,  
for your frames to be the stars.



Contact your accountmanager



JONATAN GRIEVER

jonatan@topvision.nl  
+31 (0)6 4801 0480



ROB DE WOLF

rob@topvision.nl  
+31 (0)6 5373 7827



FRANCIS PETERS

francis@topvision.nl  
+31 (0)6 4155 8035



ALEXIA PAGLIAROLI

alexia@topvisiongroup.fr  
+31 23 5176 651  
(Service-Commercial FR)

# CARRÉ

WE APPRECIATED THE SUPPORT FROM:

---

Blake Kuwahara  
Calvin Klein  
Dita  
Emmanuelle Khanh  
Face à Face  
Gouverneur  
J.F. Rey  
Jos Eyewear  
Kilsgaard  
Kirk & Kirk  
L.A. Eyeworks

Liu Jo  
Lunor  
Masunaga  
Morel  
OGI  
Oliver Goldsmith  
Ørgreen  
Prodesign  
Res / Rei  
Rodenstock  
Scotch & Soda

Serengeti  
Titanflex  
Victoria Beckham  
VM L'Atelier  
Woow  
Fagerhult Nederland  
Pols Potten  
Mertens optiek & Tempel optiek  
Beeldkrakers (video & photography)  
Maarten Weidema (text & graphic design)  
Ivar Hamelink (catalog design)

---